

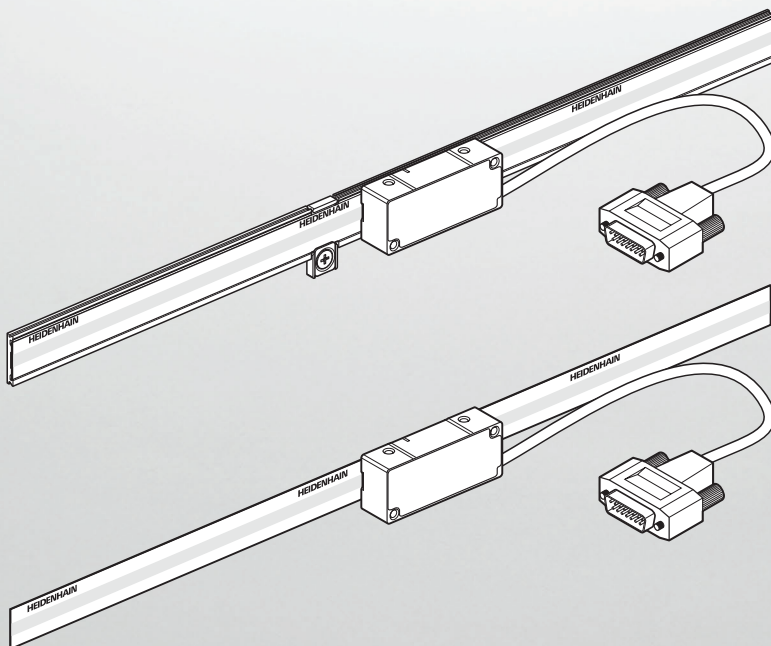

# HEIDENHAIN

## LIC 21x7 LIC 21x9

Mounting Instructions



English (en)  
08/2025

## Table of contents

<b>1</b>	<b>Basic information.....</b>	<b>4</b>
1.1	Validity of the documentation.....	4
1.2	Target groups of the Mounting Instructions.....	4
1.3	Notes on reading the documentation.....	5
1.4	Symbols and fonts used for marking text.....	6
1.5	Notes in this documentation.....	7
1.6	Units and tolerances.....	7
<b>2</b>	<b>Safety.....</b>	<b>8</b>
2.1	Personnel qualification.....	8
2.2	General safety precautions.....	8
<b>3</b>	<b>Items supplied and accessories.....</b>	<b>10</b>
3.1	Items supplied.....	10
3.1.1	Items supplied: Scale tape.....	10
3.1.2	Items supplied: LIC 21x7 scale-tape carrier section.....	10
3.1.3	Items supplied: Scanning head.....	11
3.2	Mounting accessories.....	12
3.2.1	Accessories for mounting the scale tape.....	12
3.3	Accessories for diagnostics.....	13
<b>4</b>	<b>Mounting.....</b>	<b>14</b>
4.1	Requirements and notes.....	14
4.2	Mounting the scale tape.....	15
4.2.1	Choosing the mounting variant.....	15
4.2.2	LIC 21x7: Mounting with scale-tape carrier sections.....	16
4.2.3	LIC 21x9: Mounting with adhesive film.....	22
4.3	Mounting the scanning head.....	25
4.3.1	Choosing the mounting variant.....	25
4.3.2	Variant: Mounting with the holder on the side.....	26

4.3.3 Variant: Mounting with the holder at top.....	29
4.3.4 Variant: Mounting with the holder at bottom.....	32
<b>5 Diagnostics.....</b>	<b>35</b>
<b>5.1 Continuity check.....</b>	<b>35</b>
5.1.1 Materials and tools.....	35
5.1.2 Measuring the electrical resistance.....	35
<b>5.2 Diagnostics.....</b>	<b>36</b>
<b>6 Final steps.....</b>	<b>37</b>
<b>6.1 Connecting the encoder to the downstream electronics.....</b>	<b>37</b>
<b>7 Removal.....</b>	<b>38</b>
<b>7.1 Safety precautions regarding removal.....</b>	<b>38</b>
<b>7.2 Removing the scanning head.....</b>	<b>38</b>
<b>7.3 Removing the scale tape.....</b>	<b>38</b>

## 1 Basic information

This chapter contains information about the product and the Mounting Instructions.

### 1.1 Validity of the documentation

These Mounting Instructions apply to LIC 2107, LIC 2109, LIC 211, LIC 213, LIC 219.

- Before using the documentation, check whether the documentation and product model match. The designation of the product is printed on the ID label.

#### ID label

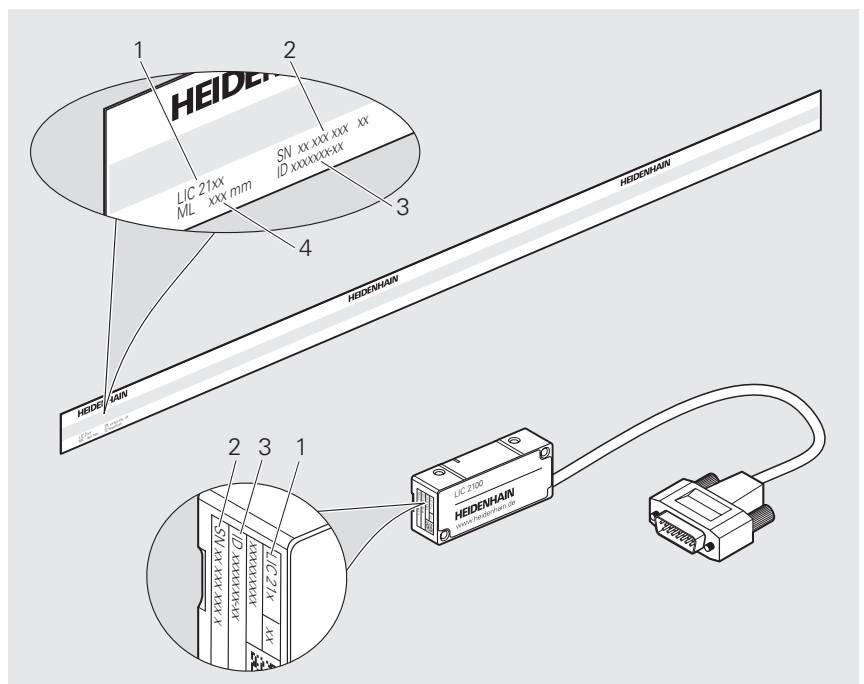

ID label with legend

- 1 Product name
- 2 Serial number (SN)
- 3 Product ID / Part number (ID)
- 4 Measuring length (ML)

### 1.2 Target groups of the Mounting Instructions

The Mounting Instructions must be read and observed by every person who performs any of the following tasks:

- Design
- Mounting
- Removal

## 1.3 Notes on reading the documentation

### WARNING

#### **Fatal accidents, personal injury or property damage caused by non-compliance with the documentation!**

Failure to comply with the documentation may result in fatal accidents, personal injury or property damage.

- ▶ Read the documentation carefully from beginning to end
- ▶ Keep the documentation for future reference

The following table lists the various parts of the documentation in their order of reading priority.

Document type	Description
Addendum	An Addendum supplements or supersedes the corresponding contents of the Operating Instructions and, if applicable, of the Mounting Instructions. If an Addendum is included in the shipment, it has the highest priority for reading. All other documentation content retains its validity.
Operating Instructions	The Operating Instructions contain all of the information and safety instructions for the proper and intended operation of the device. The Operating Instructions (English language version) are included in delivery and can also be downloaded in other languages from <b><a href="http://www.heidenhain.com/documentation">www.heidenhain.com/documentation</a></b> . The Operating Instructions must be read prior to initial operation of the product. The Operating Instructions have the second highest priority for reading.
Mounting Instructions	The Mounting Instructions contain all the information and safety precautions needed for the proper mounting and installation of a product. The Mounting Instructions are not included in delivery and must be downloaded from <b><a href="http://www.heidenhain.com/documentation">www.heidenhain.com/documentation</a></b> . The Mounting Instructions have the third highest priority for reading.

#### **Would you like any changes, or have you found any errors?**

We are continuously striving to improve our documentation for you. Please help us by sending your suggestions to the following e-mail address:

**[userdoc@heidenhain.de](mailto:userdoc@heidenhain.de)**

## 1.4 Symbols and fonts used for marking text

In these instructions the following symbols and fonts are used for marking text:

Format	Meaning
▶ ...	Identifies an action and the result of this action
> ...	Example: <ul style="list-style-type: none"> <li>▶ Tilt the shipping brace to remove it <b>(c)</b></li> <li>&gt; The shipping brace has been removed now</li> </ul>
■ ...	Identifies an item of a list
■ ...	Example: <ul style="list-style-type: none"> <li>■ Solid contaminants: class 3</li> <li>■ Max. pressure dew point: class 4</li> </ul>

## 1.5 Notes in this documentation

### Safety precautions

Precautionary statements warn of hazards in handling the product and provide information on their prevention. Precautionary statements are classified by hazard severity and divided into the following groups:

** DANGER**

**Danger** indicates hazards for persons. If you do not follow the avoidance instructions, the hazard **will result in death or severe injury**.

** WARNING**

**Warning** indicates hazards for persons. If you do not follow the avoidance instructions, the hazard **could result in death or serious injury**.

** CAUTION**

**Caution** indicates hazards for persons. If you do not follow the avoidance instructions, the hazard **could result in minor or moderate injury**.

**NOTICE**

**Notice** indicates danger to material or data. If you do not follow the avoidance instructions, the hazard **could result in property damage**.

### Informational notes

Informational notes ensure reliable and efficient operation of the product. Informational notes are divided into the following groups:

 The information symbol indicates a **tip**.  
A tip provides important additional or supplementary information.

 The book symbol indicates a **cross reference**.  
A cross reference leads to external documentation, for example: further documentation from HEIDENHAIN or another supplier.

 The globe symbol represents a **cross reference** to a source on the Internet, e.g. [www.heidenhain.com](http://www.heidenhain.com)

## 1.6 Units and tolerances

Unless otherwise specified, the dimensions stated in these Mounting Instructions are given in millimeters.

Unless otherwise specified, the tolerances stated in these Mounting Instructions conform to ISO 8015 and ISO 2768 standards.

mm   
Tolerancing ISO 8015  
ISO 2768:1989-mH  
≤ 6 mm: ±0.2 mm

## 2 Safety

This chapter provides important safety information needed for the proper mounting and installation of the product.

### 2.1 Personnel qualification

Mounting, initial configuration and removal must be conducted by a qualified specialist under compliance with local safety regulations.

### 2.2 General safety precautions

#### **WARNING**

##### **Danger of electric shock due to connection to unsuitable downstream electronics!**

If you connect unsuitable downstream electronics to the product, fatal accidents or severe personal injuries can occur.

- ▶ Connect the product only to downstream electronics whose supply voltage comes from PELV systems

#### **WARNING**

##### **Live plug connections!**

If you disengage plug connections while the equipment is under power, this may result in fatal accidents or severe personal injury.

- ▶ Do not engage or disengage any connecting elements while the product is under power

#### **WARNING**

##### **Risk of injury from damaged or worn components!**

Safety functions can fail if damaged or worn components are installed unintentionally. Failed safety functions can result in death or serious injury.

- ▶ Inspect the component for damage
- ▶ Do not use any damaged or worn components
- ▶ In case of replacement, repair the thread
- ▶ Use new screws, spring pins and nuts
- ▶ Secure screws and nuts with suitable material-bonding anti-rotation lock

#### **NOTICE**

##### **Property damage due to mechanical stress!**

- ▶ Do not drop the product or subject it to major vibration
- ▶ Do not expose the product to mechanical stress
- ▶ Do not change the physical structure of the product

**NOTICE****Property damage due to electrical stress!**

- ▶ Do not engage or disengage any connecting elements while the product is under power
- ▶ Do not touch the contacts of the plug connections

**NOTICE****Electrostatic discharge (ESD)!**

This product contains electrostatically sensitive components that can be destroyed by electrostatic discharge (ESD).



- ▶ It is essential to observe the safety precautions for handling ESD-sensitive components
- ▶ Never touch connector pins without ensuring proper grounding
- ▶ Wear a grounded ESD wristband when handling the connections of the product

### 3 Items supplied and accessories



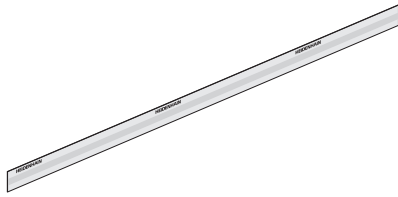
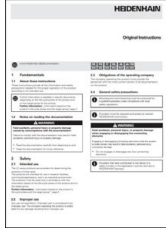

This chapter contains information on the items supplied and the available accessories of the product.

#### 3.1 Items supplied

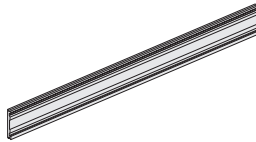

##### 3.1.1 Items supplied: Scale tape

Component	Figure
Scale tape	
Operating Instructions	
Quality Inspection Document	

##### 3.1.2 Items supplied: LIC 21x7 scale-tape carrier section

Component	Figure
Scale-tape carrier section for mounting with adhesive film	
Fixing set for clamping the scale tape	
Holder	
Fixing clamp	
Two screws	

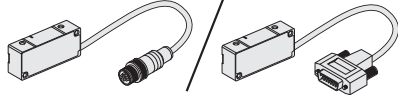
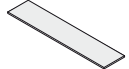
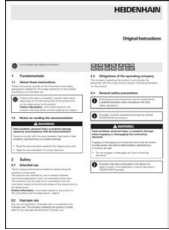
### 3.1.3 Items supplied: Scanning head

Component	Figure
Scanning head	
Spacer shim, 0.75 mm	
Operating Instructions	
Manufacturer's Inspection Document	

## 3.2 Mounting accessories

The following accessories can be ordered separately from HEIDENHAIN.



For more information on the listed products, please refer to the applicable Mounting Instructions and the **Exposed Linear Encoders** brochure.

- ▶ [www.heidenhain.com/documentation](http://www.heidenhain.com/documentation)
- ▶ Enter the document ID **208960**

### 3.2.1 Accessories for mounting the scale tape

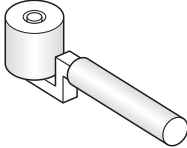
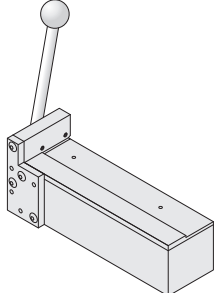
Designation	ID	Figure
Roller	276885-01	
Cut-off device	303516-01	

### 3.3 Accessories for diagnostics

Accessories can be ordered separately from HEIDENHAIN.

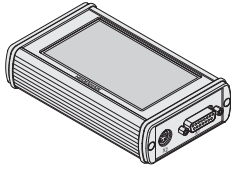
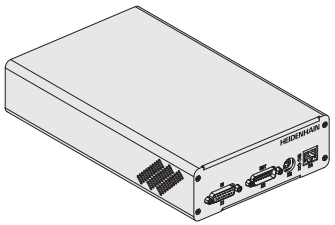
Designation	ID	Figure
PWT 101 testing device	1261013-01	
or		
PWM 21 inspection device	1200635-51	

#### Adjusting and Testing Software (ATS)

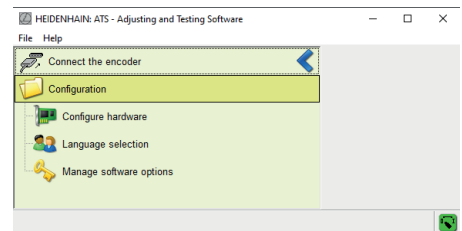

The ATS is available for download free of charge.

- ▶ [www.heidenhain.com/service/downloads/software/](http://www.heidenhain.com/service/downloads/software/)
- ▶ Open the **Categories** selection menu
- ▶ Select the **Inspection and testing devices** category

## 4 Mounting

This chapter describes the mounting requirements, different mounting variants, and all other tasks necessary when mounting.

### 4.1 Requirements and notes

#### NOTICE

##### Property damage due to inappropriate tools!

Using inappropriate tools for mounting or removal of the encoder may cause damage to the encoder.

- ▶ Do not use hammers
- ▶ Do not use pointed or sharp-edged tools

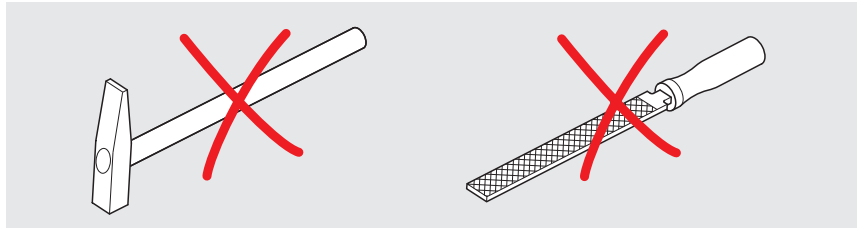

Choose a mounting attitude such that the traverse range is within the measuring length (**ML**) of the encoder.

(**S**) = Beginning of measuring length (**ML**)

Protect the graduation from direct contamination.

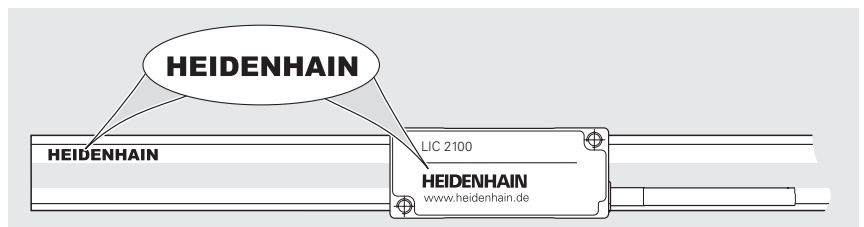
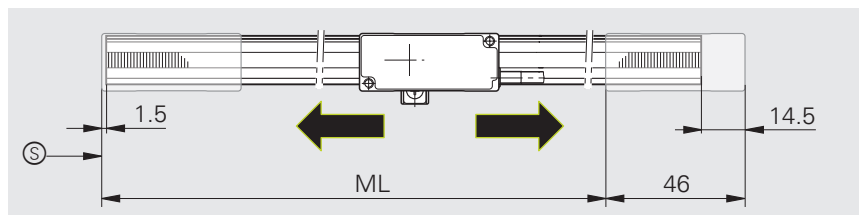

In order to avoid signal interferences, observe the minimum clearance from sources of interference (e.g., power lines).



For more information on sources of interference, refer to the **Interfaces of HEIDENHAIN Encoders** brochure.

- ▶ [www.heidenhain.com/documentation](http://www.heidenhain.com/documentation)
- ▶ Enter the document ID **1078628**



For more information on mounting, refer to the **Mating Dimensions** document.

- ▶ [www.heidenhain.com/documentation](http://www.heidenhain.com/documentation)
- ▶ Enter the product ID
- ▶ Open **Mating Dimensions**

## 4.2 Mounting the scale tape

### 4.2.1 Choosing the mounting variant

#### Mounting variants for the scale tape

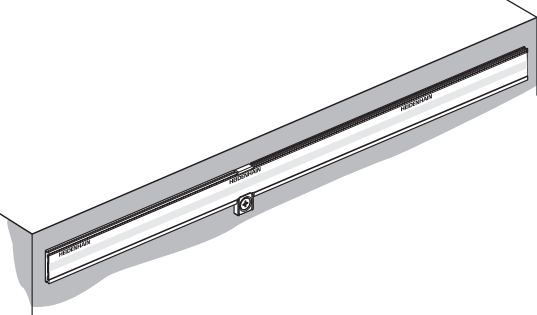
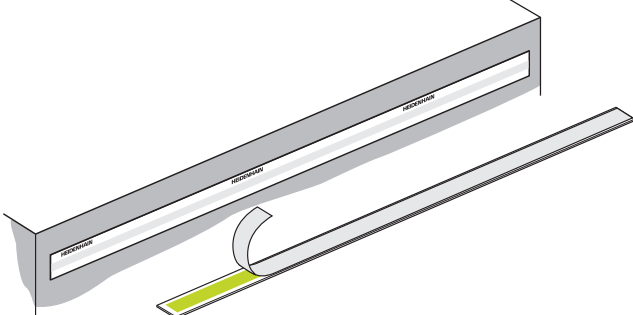
LIC 21x7: Mounting <b>with scale-tape carrier sections</b>	LIC 21x9: Mounting <b>with adhesive film</b>
 <p>The diagram illustrates the LIC 21x7 scale tape mounted on a carrier section. The carrier section is a long, narrow, rectangular component with a central channel. The scale tape is inserted into this channel and is held in place by a small metal clip or fastener. The carrier section has a slightly raised edge on one side.</p>	 <p>The diagram illustrates the LIC 21x9 scale tape mounted with adhesive film. The scale tape is shown being applied to a carrier section. A strip of adhesive film is being rolled onto the back of the scale tape, which is then pressed onto the carrier section. The carrier section has a similar profile to the LIC 21x7 variant but is wider.</p>
<p><b>Page 16</b></p>	<p><b>Page 22</b></p>

### 4.2.2 LIC 21x7: Mounting with scale-tape carrier sections

The mounting variant described in this chapter refers to mounting of the scale tape with scale-tape carrier sections. An overview of the mounting variants is provided on Page 15.

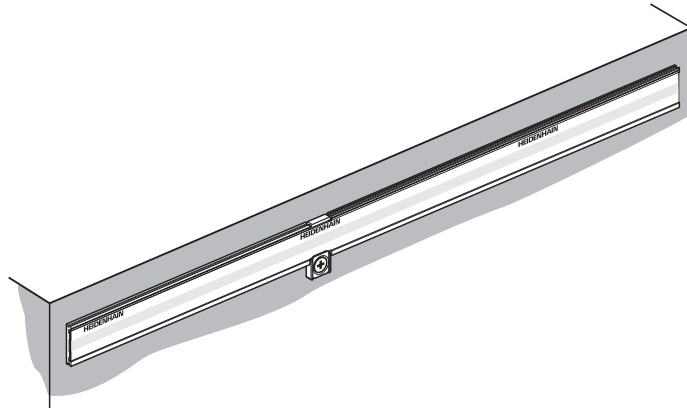

#### Mounting information

Note that the mounting surface, as well as the surface of the scale tape, must be clean and free of paint, dust or grease.

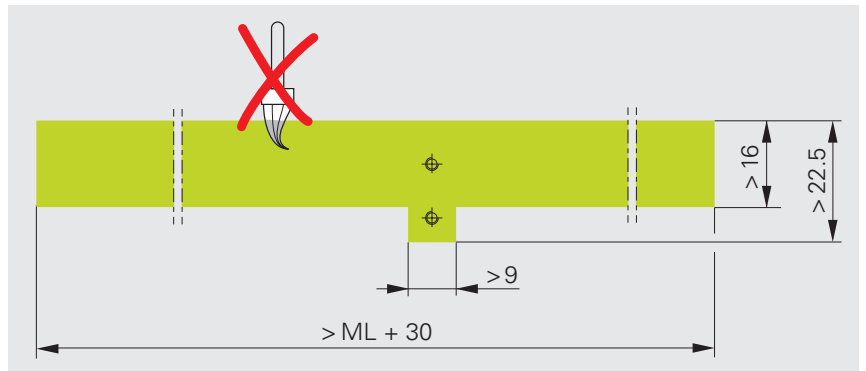

- T = Scale-tape carrier section
- H = Holder
- S = Fixing clamp

**i** If necessary, you can shorten the scale tape carriers with a suitable tool.

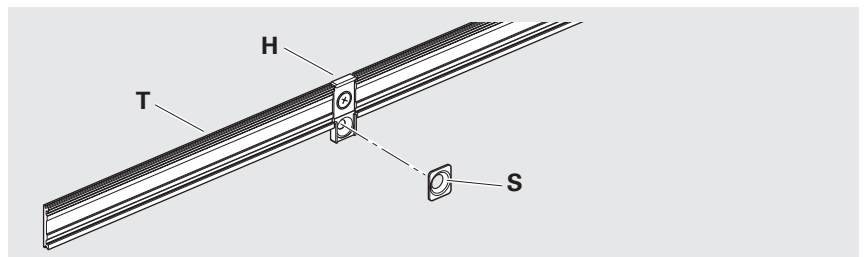

The mounting tolerances refer to the machine guideway (F).

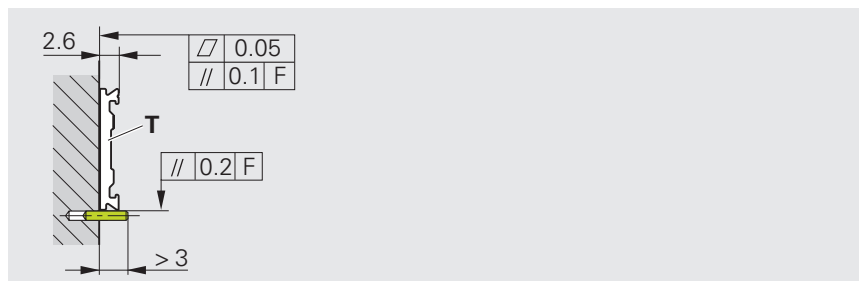

Comply with the specified dimensions to account for thermal expansion.

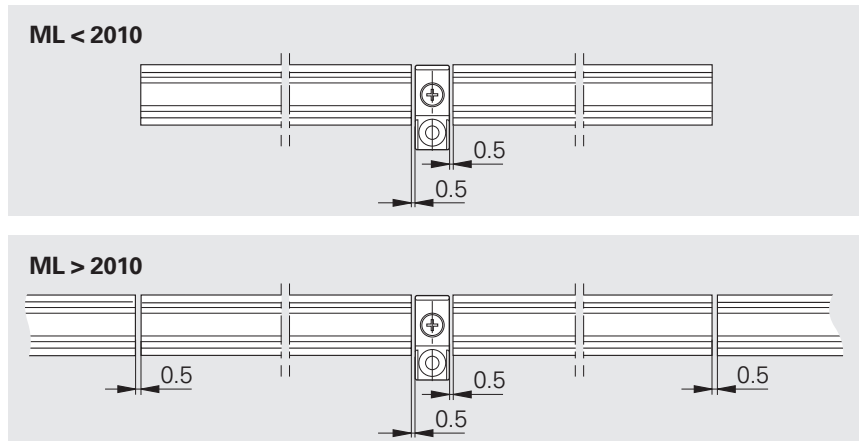

### Materials and tools

For this task, the following materials and tools are needed:

#### Included in delivery

- Holder
- Fixing clamp
- Two screws (ISO 7046 – M3x6)

#### To be provided separately

- Stop pins
- Scale-tape carrier sections
- Torque wrench (hexagon socket for 2.5 mm)
- Roller

### Bonding the scale tape carrier

- ▶ Insert the stop pins

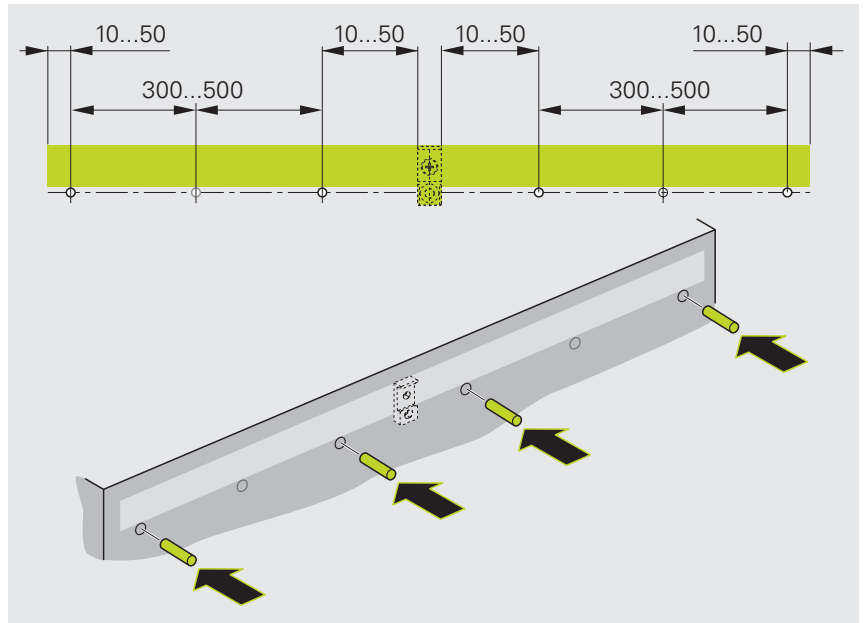

- ▶ Mount the holder and tighten the screw using the specified torque

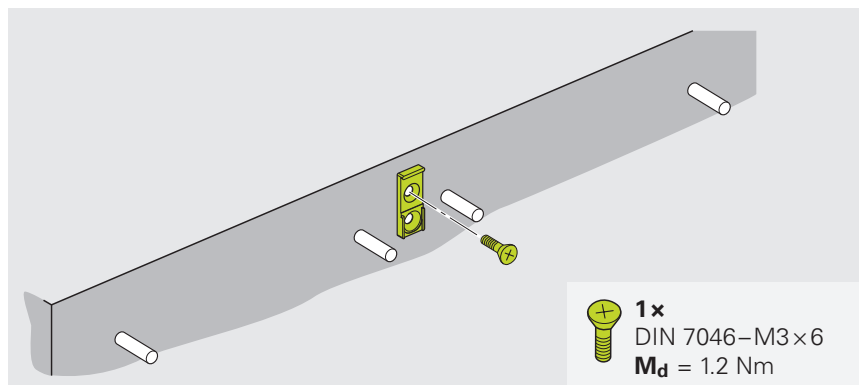

Attach the scale tape carrier with adhesive mounting film only at a temperature of  $> 15\text{ }^{\circ}\text{C}$ .

Pay attention to the expiration date on the package.

- ▶ Remove the protective foil from the adhesive film

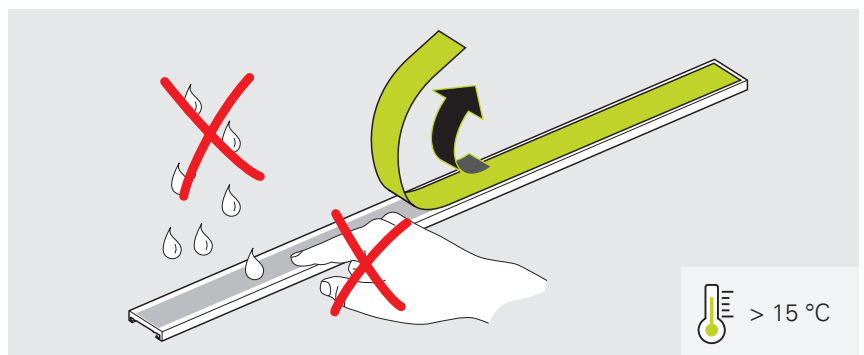

Ensure that the scale tape carriers are positioned correctly.

- ▶ Carefully place the scale tape carriers onto the stop pins
- ▶ Push the scale tape carriers against the mounting surface and lightly press them against the mounting surface

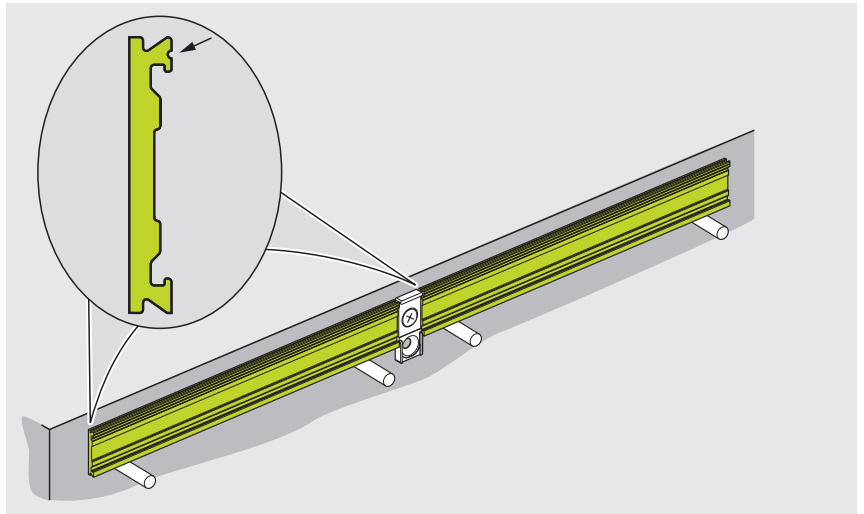

- ▶ Starting from the center, evenly press the scale-tape carriers onto the mounting surface using the roller

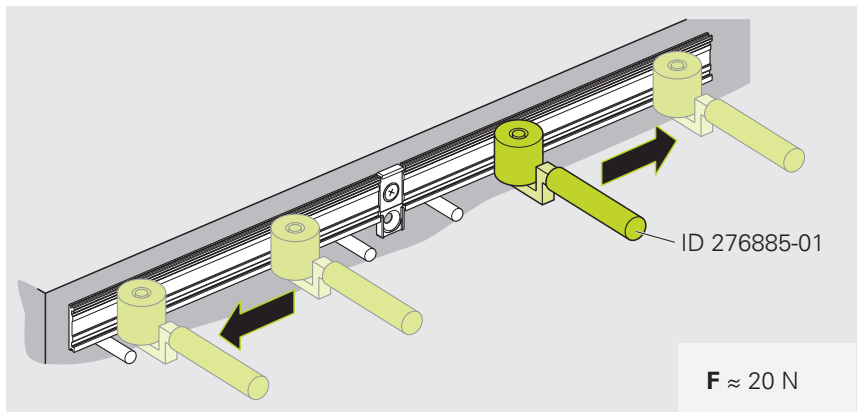

- ▶ Remove the stop pins
- ▶ Do not perform further work on the scale-tape carrier until the maximum adhesive force has been reached.

**i** The maximum adhesive force of the mounting film is reached at room temperature after approx. 70 hours.

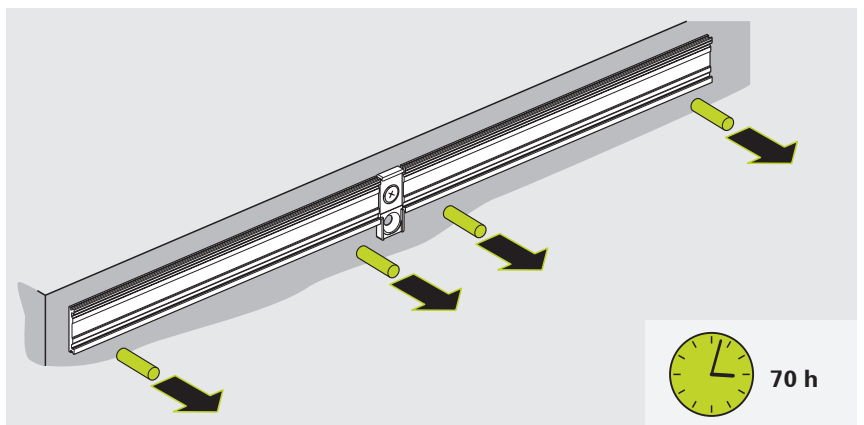

## Mounting the scale tape

### NOTICE

#### Property damage due to mechanical stress!

- ▶ Do not bend the scale tape

- ▶ If necessary, shorten the scale tape to the desired length. Cut only on the indicated side

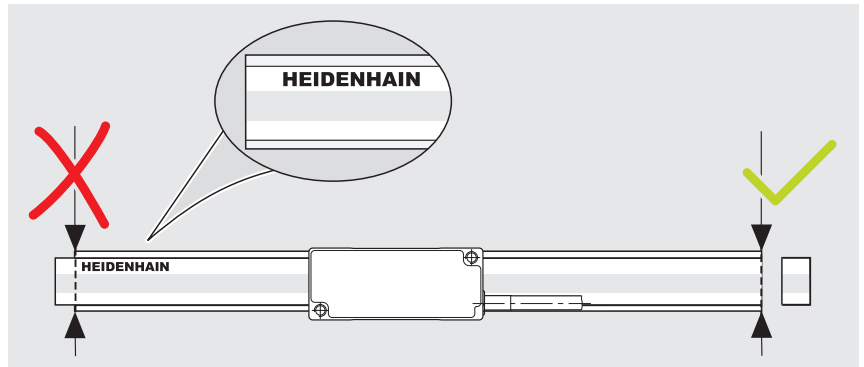

- ▶ If necessary, remove the protective film from the scale tape

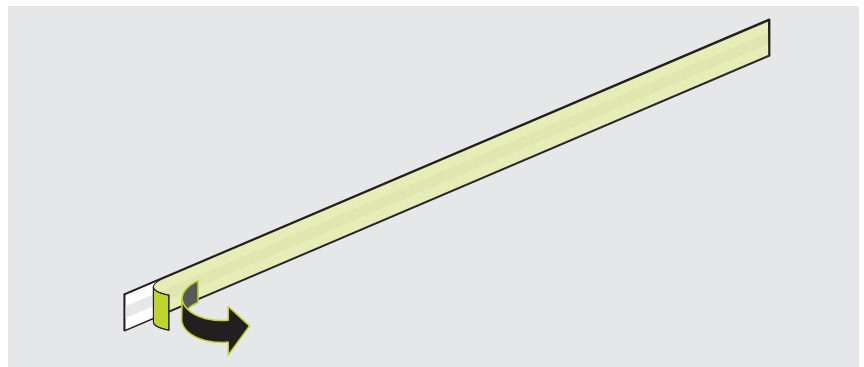

- ▶ Slide the scale tape into the scale-tape carrier

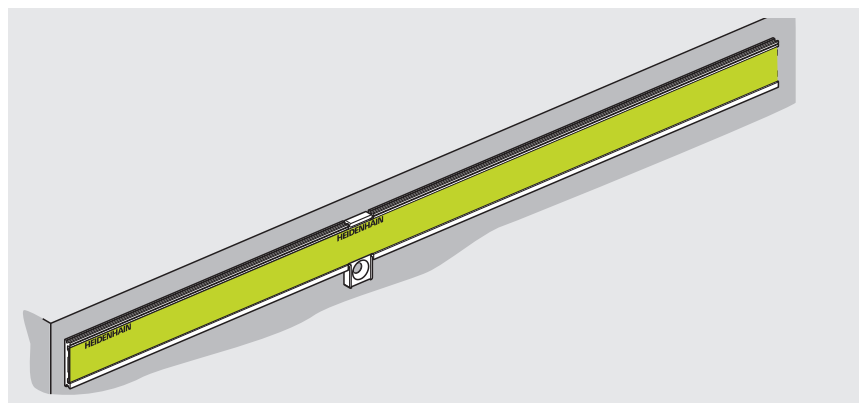

- ▶ Mount the fixing clamp and tighten the screw using the specified torque

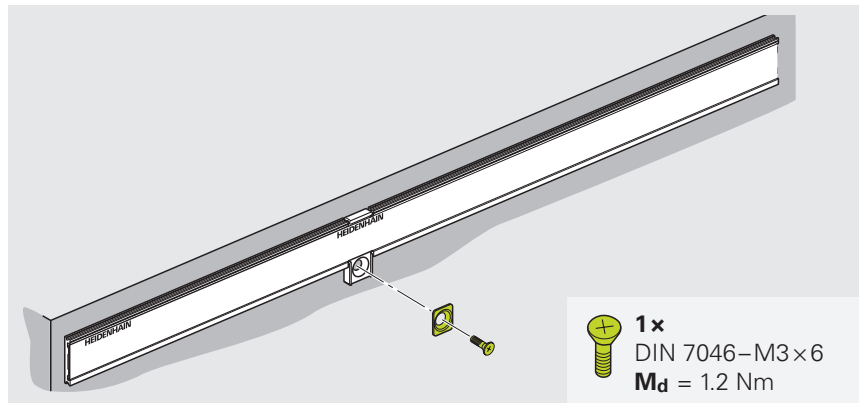

**Next step:** "Mounting the scanning head", Page 25

### 4.2.3 LIC 21x9: Mounting with adhesive film

The mounting variant described in this chapter refers to mounting of the scale tape with adhesive film.

An overview of the mounting variants is provided on Page 15.

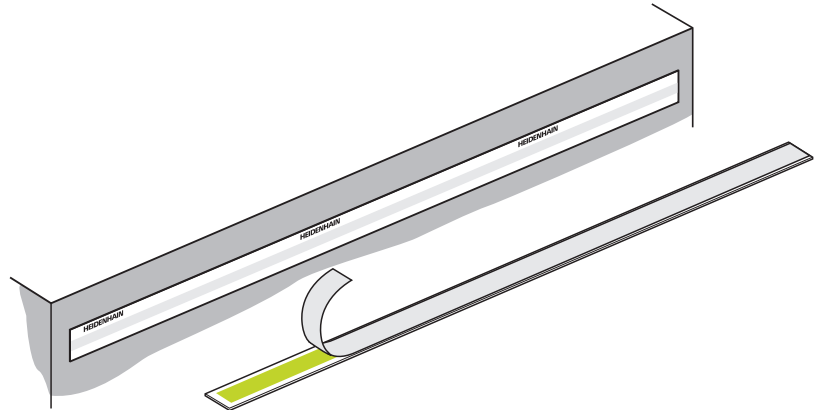

#### Mounting information

Note that the mounting surface, as well as the surface of the scale tape, must be clean and free of paint, dust or grease.

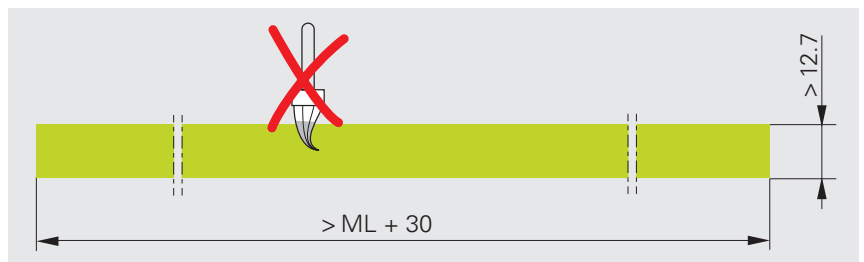

The mounting tolerances refer to the machine guideway (F).

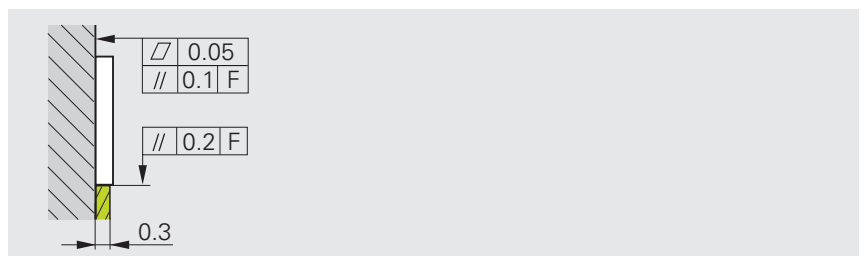

#### Materials and tools

For this task, the following materials and tools are needed:

##### Included in delivery

##### To be provided separately

- Aligning rail
- Roller

**Bonding the scale tape**

**NOTICE**

**Property damage due to mechanical stress!**

- ▶ Do not bend the scale tape

- ▶ If necessary, shorten the scale tape to the desired length. Cut only on the indicated side

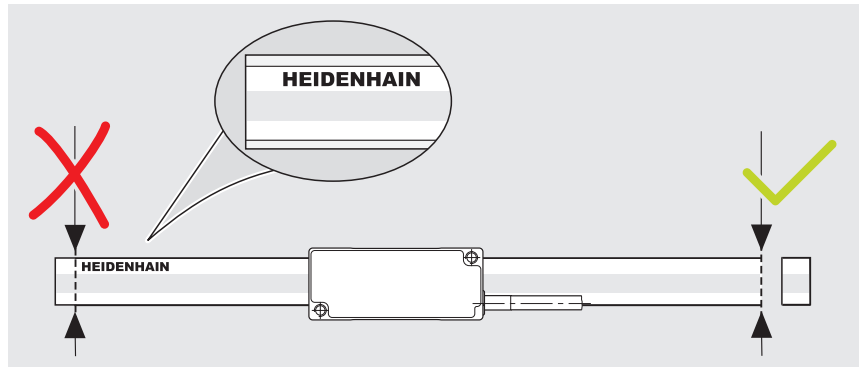

Attach the scale tape with adhesive mounting film only at a temperature of > 15 °C.

Pay attention to the expiration date on the package.

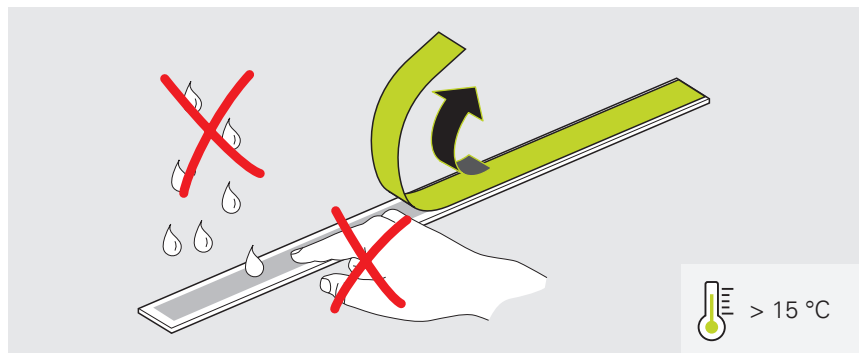

- ▶ Attach the aligning rail
- ▶ Remove about one-third of the protective foil from the adhesive film
- ▶ Gently glue the scale tape along the aligning rail. Remove the protective film while doing so

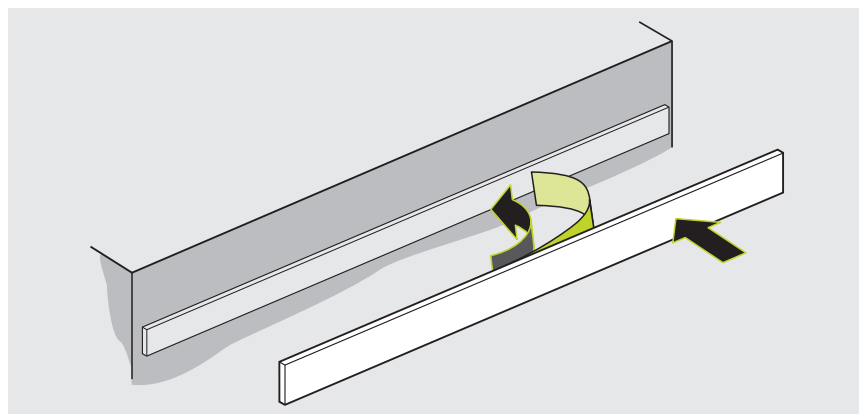

- ▶ Starting from the center, evenly press the scale tape onto the mounting surface using the roller
- ▶ Remove the aligning rail

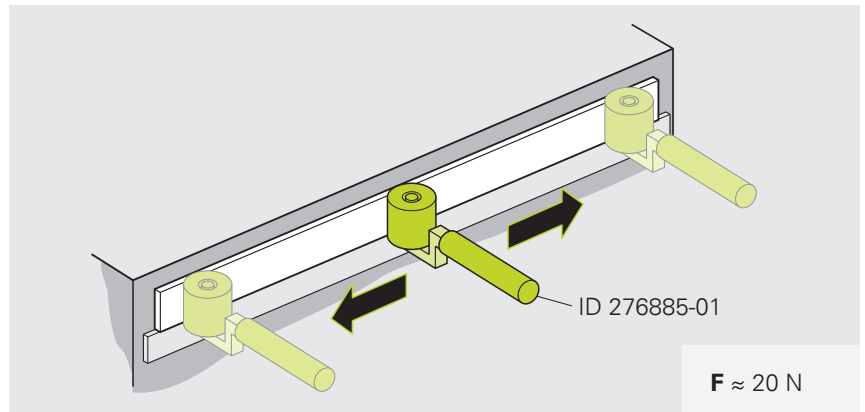

- ▶ Do not perform further work on the scale tape until the maximum adhesive force has been reached

**i** The maximum adhesive force of the mounting film is reached at room temperature after approx. 70 hours.

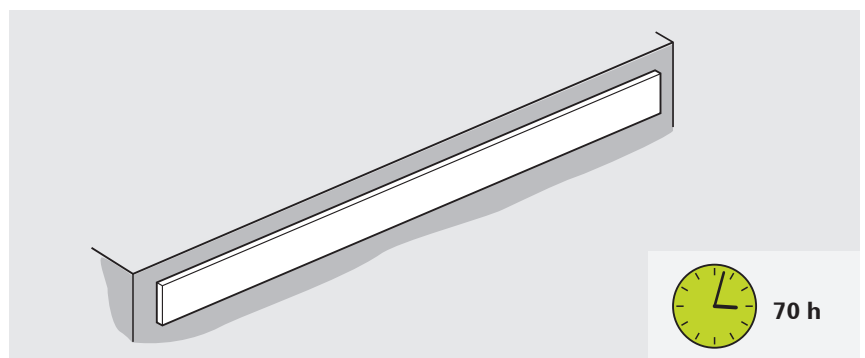

**Next step:** "Mounting the scanning head", Page 25

### 4.3 Mounting the scanning head

#### 4.3.1 Choosing the mounting variant

**Mounting variants for the scanning head**

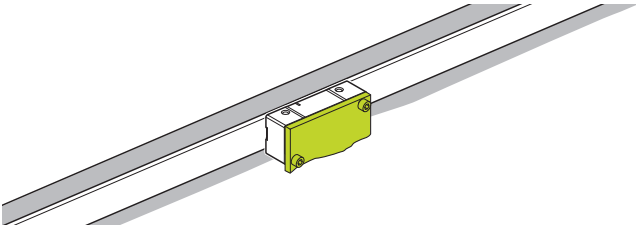
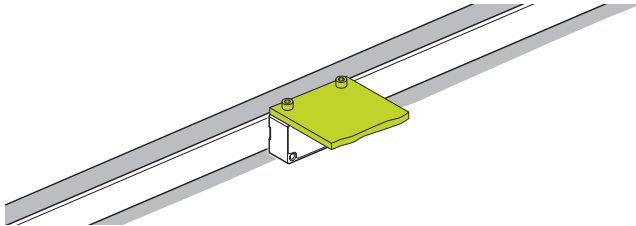
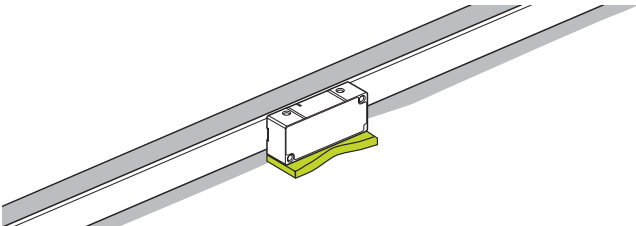
Holder <b>on the side</b>	Holder <b>at the top</b>
 <p><b>Page 26</b></p>	 <p><b>Page 29</b></p>
<p>Holder at the <b>bottom</b></p>  <p><b>Page 32</b></p>	

### 4.3.2 Variant: Mounting with the holder on the side

The mounting variant described in this chapter refers to mounting of the scanning head with the holder on the side.

An overview of the mounting variants is provided on Page 25.

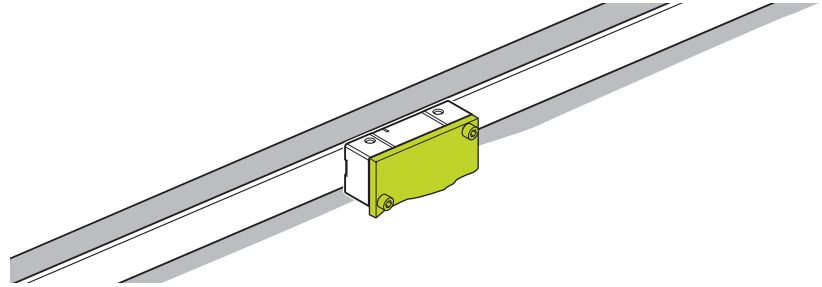

#### Notes on mounting the scanning head with the holder on the side



The tightening torques of the mounting screws are only valid for mounting on steel.

#### CAUTION

##### Irritation from isopropyl alcohol

Contact with isopropyl alcohol or inhaling isopropyl alcohol fumes can cause irritation affecting the skin, eyes, or respiratory system.

- ▶ Wear protective gloves and safety goggles
- ▶ Wear respiratory protection
- ▶ Keep the workplace well ventilated
- ▶ Comply with the manufacturer's safety data sheets

#### NOTICE

##### Property damage due to unsuitable cleaning agents!

The use of inappropriate cleaning agents causes damage to the encoder.

- ▶ Use only isopropyl alcohol to clean the encoder
- ▶ Clean the encoder with a lint-free cloth

- ▶ If necessary, clean the graduation and the scanning head with a lint-free cloth and isopropyl alcohol

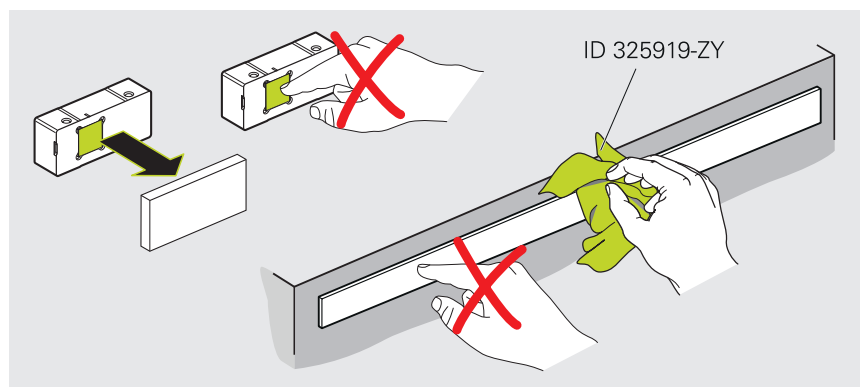

Pay attention to the mounting dimensions. Deviations from the mounting dimensions lead to imprecise measurement results during operation.

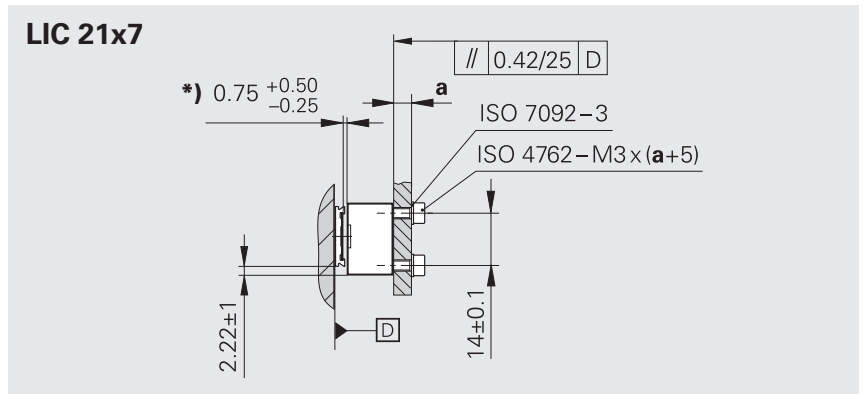

\*) Mounting clearance between the scanning head and graduation.

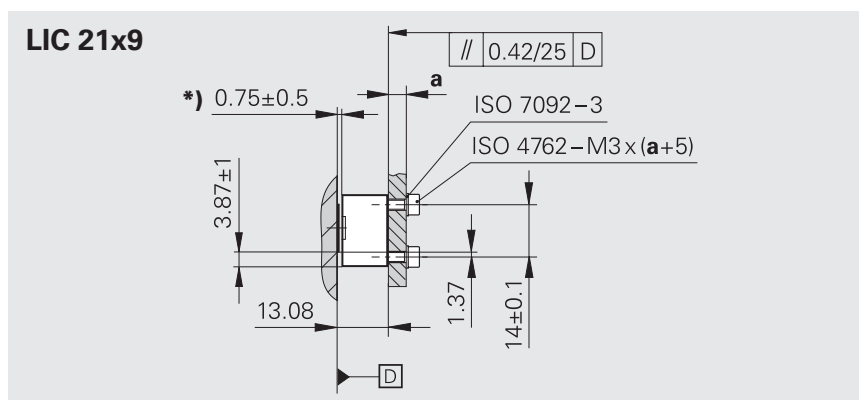

\*) Mounting clearance between the scanning head and graduation.

### Materials and tools

For this task, the following materials and tools are needed:

#### Included in delivery

- Spacer shim

#### To be provided separately

- Two screws (ISO 4762-M3x(a+5))
- Two washers (ISO 7092-3)
- Torque wrench (hexagon socket for 2.5 mm)

### Mounting the scanning head

- ▶ If necessary, remove the protective cap from the scanning head
- ▶ If necessary, remove the protective film from the scale tape

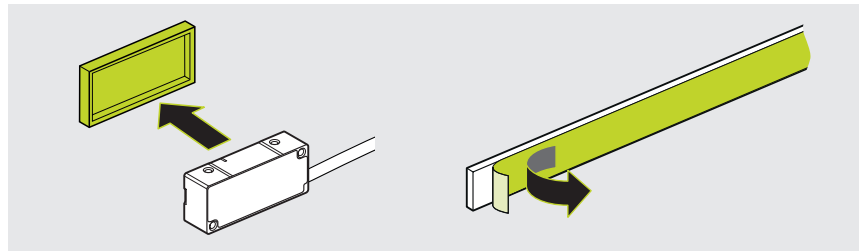

- ▶ Prepare the spacer shim
- ▶ If necessary, clean the spacer shim with a lint-free cloth and isopropyl alcohol

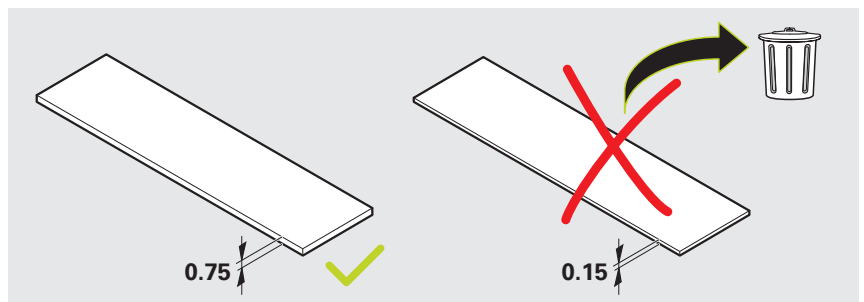

**i** When mounting the scale tape with scale-tape carrier sections: Do not place the spacer shim over the scale-tape carrier sections.

- ▶ Use the spacer shim to set the mounting clearance
- ▶ Fasten the scanning head with the specified torque
- ▶ Remove the spacer shim

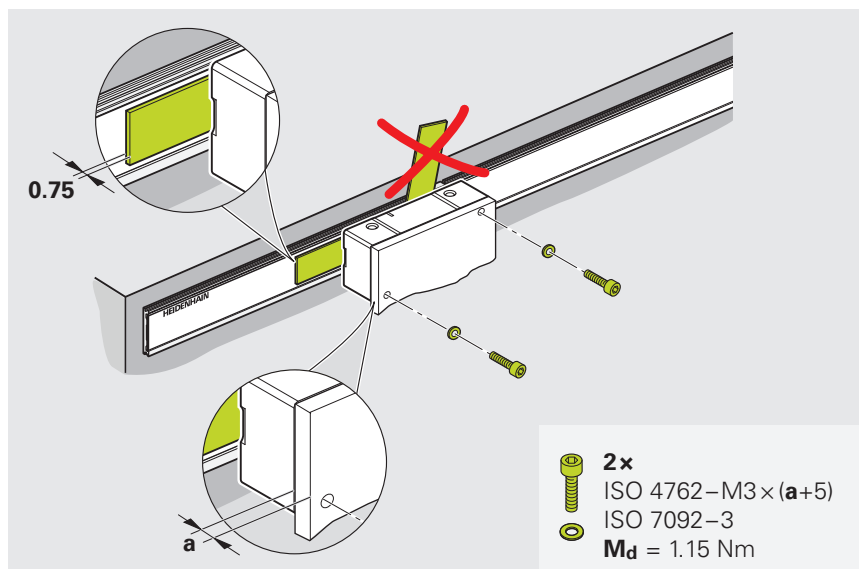

**Next step:** "Diagnostics", Page 35

### 4.3.3 Variant: Mounting with the holder at top

The mounting variant described in this chapter refers to mounting of the scanning head with the holder at top. An overview of the mounting variants is provided on Page 25.

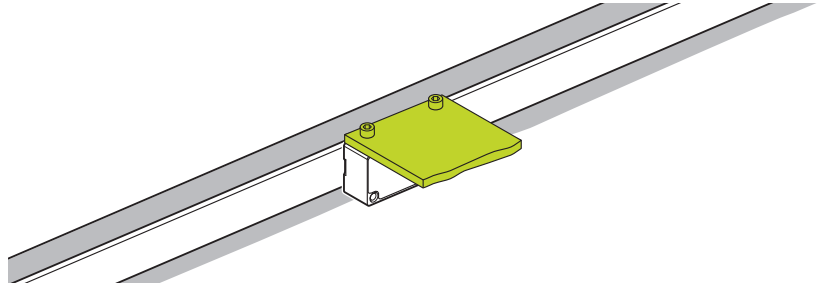

#### Notes on mounting the scanning head with the holder on the side

**i** The tightening torques of the mounting screws are only valid for mounting on steel.

#### CAUTION

**Irritation from isopropyl alcohol**

Contact with isopropyl alcohol or inhaling isopropyl alcohol fumes can cause irritation affecting the skin, eyes, or respiratory system.

- ▶ Wear protective gloves and safety goggles
- ▶ Wear respiratory protection
- ▶ Keep the workplace well ventilated
- ▶ Comply with the manufacturer's safety data sheets

#### NOTICE

**Property damage due to unsuitable cleaning agents!**

The use of inappropriate cleaning agents causes damage to the encoder.

- ▶ Use only isopropyl alcohol to clean the encoder
- ▶ Clean the encoder with a lint-free cloth

▶ If necessary, clean the graduation and the scanning head with a lint-free cloth and isopropyl alcohol

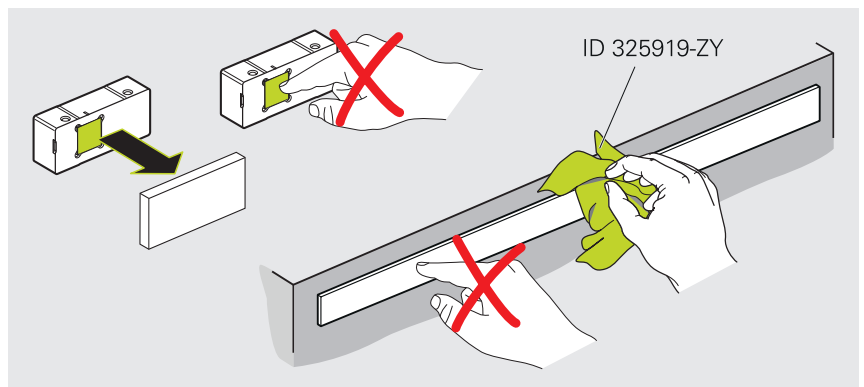

Pay attention to the mounting dimensions. Deviations from the mounting dimensions lead to imprecise measurement results during operation.

### LIC 21x7

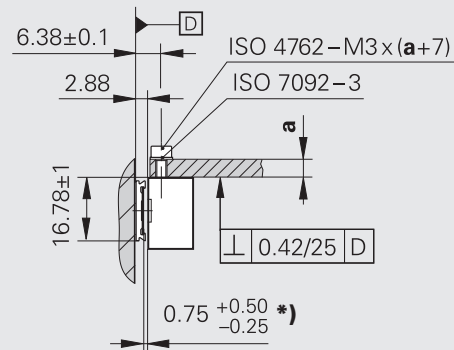

\*) Mounting clearance between the scanning head and graduation.

### LIC 21x9

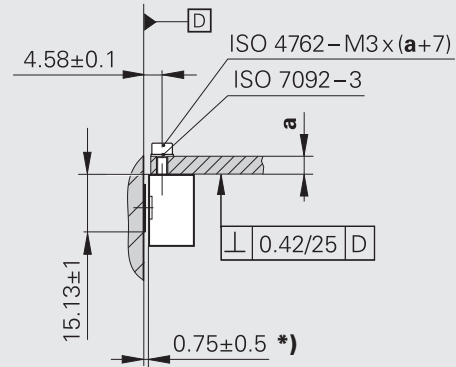

\*) Mounting clearance between the scanning head and graduation.

### Materials and tools

For this task, the following materials and tools are needed:

#### Included in delivery

- Spacer shim

#### To be provided separately

- Two screws (ISO 4762-M3x(a+7))
- Two washers (ISO 7092-3)
- Torque wrench (hexagon socket for 2.5 mm)

**Mounting the scanning head**

- ▶ If necessary, remove the protective cap from the scanning head
- ▶ If necessary, remove the protective film from the scale tape

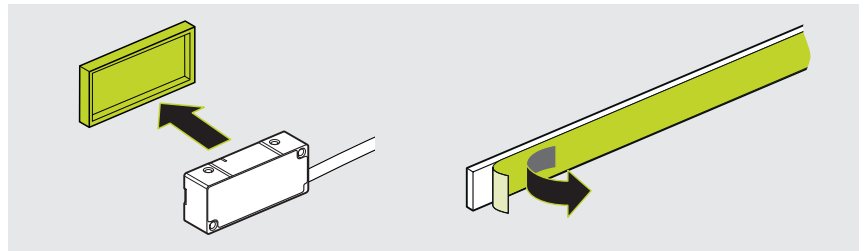

- ▶ Prepare the spacer shim
- ▶ If necessary, clean the spacer shim with a lint-free cloth and isopropyl alcohol

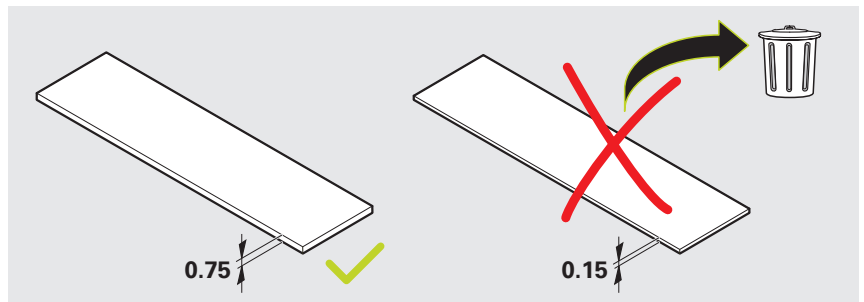

**i** When mounting the scale tape with scale-tape carrier sections:  
Do not place the spacer shim over the scale-tape carrier sections.

- ▶ Use the spacer shim to set the mounting clearance
- ▶ Fasten the scanning head with the specified torque
- ▶ Remove the spacer shim

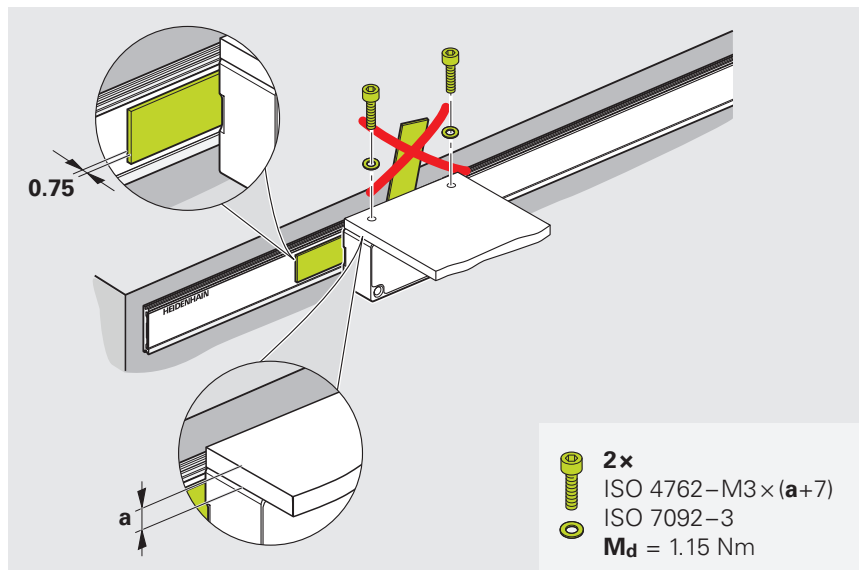

**Next step:** "Diagnostics", Page 35

#### 4.3.4 Variant: Mounting with the holder at bottom

The mounting variant described in this chapter refers to mounting of the scanning head with the holder at bottom.

An overview of the mounting variants is provided on Page 25.

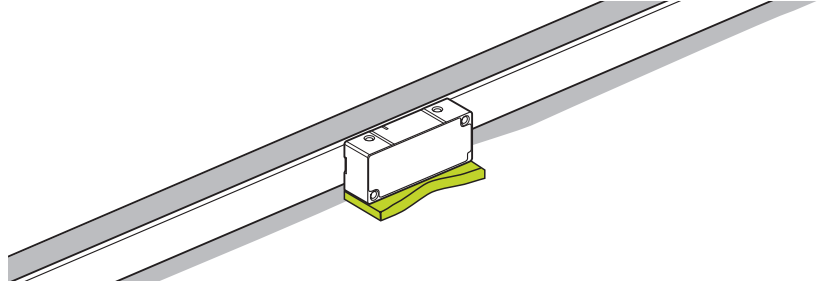

#### Notes on mounting the scanning head with the holder on the side



The tightening torques of the mounting screws are only valid for mounting on steel.

#### CAUTION

##### Irritation from isopropyl alcohol

Contact with isopropyl alcohol or inhaling isopropyl alcohol fumes can cause irritation affecting the skin, eyes, or respiratory system.

- ▶ Wear protective gloves and safety goggles
- ▶ Wear respiratory protection
- ▶ Keep the workplace well ventilated
- ▶ Comply with the manufacturer's safety data sheets

#### NOTICE

##### Property damage due to unsuitable cleaning agents!

The use of inappropriate cleaning agents causes damage to the encoder.

- ▶ Use only isopropyl alcohol to clean the encoder
- ▶ Clean the encoder with a lint-free cloth

- ▶ If necessary, clean the graduation and the scanning head with a lint-free cloth and isopropyl alcohol

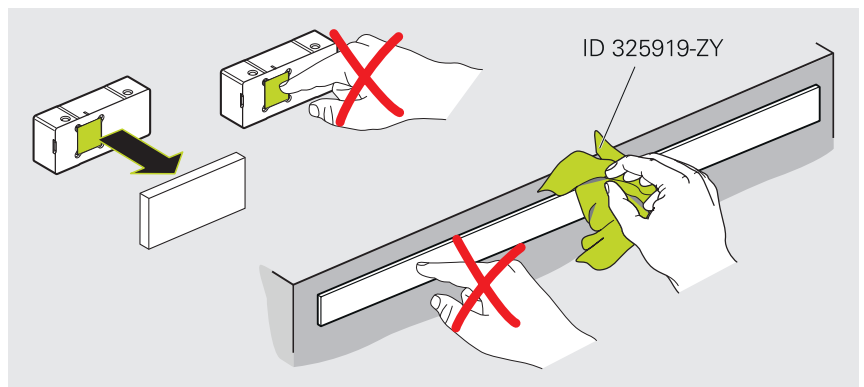

Pay attention to the mounting dimensions. Deviations from the mounting dimensions lead to imprecise measurement results during operation.

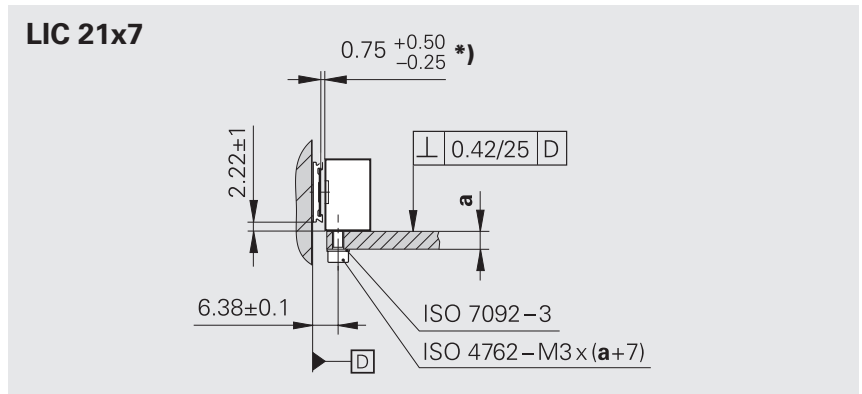

\*) Mounting clearance between the scanning head and graduation.

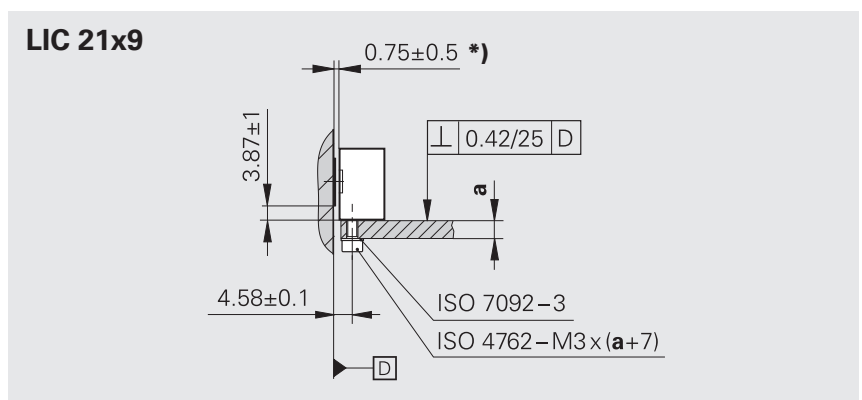

\*) Mounting clearance between the scanning head and graduation.

### Materials and tools

For this task, the following materials and tools are needed:

#### Included in delivery

- Spacer shim

#### To be provided separately

- Two screws (ISO 4762-M3x(a+7))
- Two washers (ISO 7092-3)
- Torque wrench (hexagon socket for 2.5 mm)

### Mounting the scanning head

- ▶ If necessary, remove the protective cap from the scanning head
- ▶ If necessary, remove the protective film from the scale tape

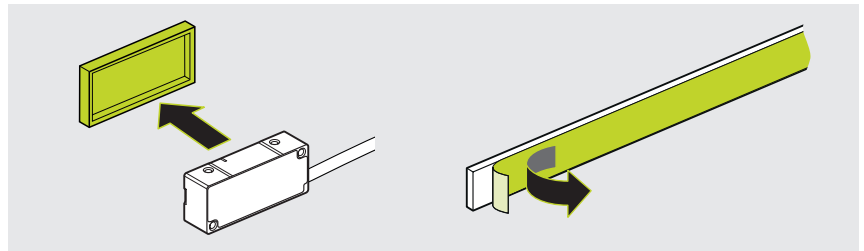

- ▶ Prepare the spacer shim
- ▶ If necessary, clean the spacer shim with a lint-free cloth and isopropyl alcohol

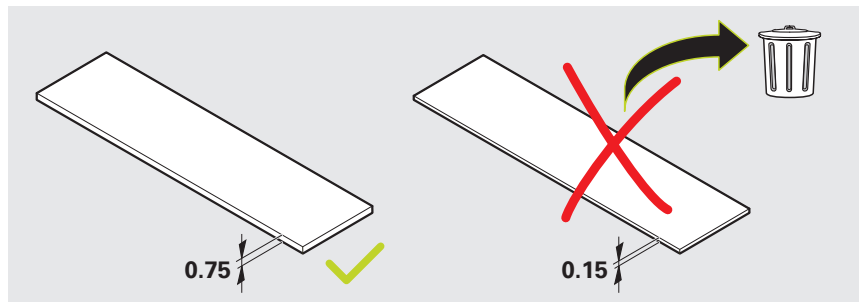

**i** When mounting the scale tape with scale-tape carrier sections: Do not place the spacer shim over the scale-tape carrier sections.

- ▶ Use the spacer shim to set the mounting clearance
- ▶ Fasten the scanning head with the specified torque
- ▶ Remove the spacer shim

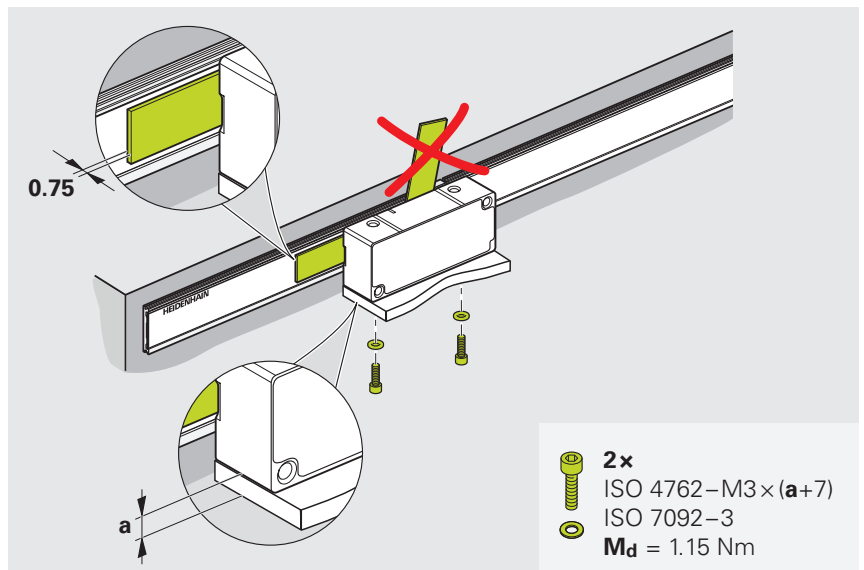

**Next step:** "Diagnostics", Page 35

## 5 Diagnostics

This chapter describes the continuity test and diagnostics using a testing device (e.g., PWT 101) or inspection device (e.g., PWM 21).

### 5.1 Continuity check

#### 5.1.1 Materials and tools

For this mounting step, the following materials and tools are needed:

##### Included in delivery

##### To be provided separately

- Resistance measuring device

#### 5.1.2 Measuring the electrical resistance

- ▶ Check the electrical resistance between the connector housing and the machine



The electrical resistance between the connector housing and the machine must be  $< 1 \Omega$ .

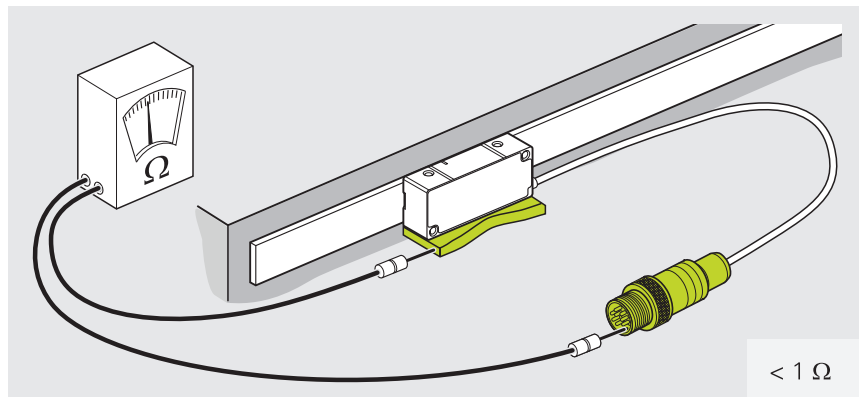

## 5.2 Diagnostics

A testing device (e.g., PWT 101) or inspection device (e.g., PWM 21) is needed for the diagnosis.

The PWM 21 inspection device consists of the following components:

- PWM 21
- ATS – if a special version (SVxx.x.x) for a specific device is available, use the special version. If no special version is available, use the latest version (Vx.x.xx).



The ATS is available for download free of charge.

- ▶ [www.heidenhain.com/service/downloads/software/](http://www.heidenhain.com/service/downloads/software/)
- ▶ Open the **Categories** selection menu
- ▶ Select the **Inspection and testing devices** category



For more information, refer to the applicable **Adjusting and Testing Software** documentation.

- ▶ [www.heidenhain.com/documentation](http://www.heidenhain.com/documentation)
- ▶ Enter the document ID **543734**



For more information, refer to the **PWT 100/PWT 101** Operating Instructions.

- ▶ [www.heidenhain.com/documentation](http://www.heidenhain.com/documentation)
- ▶ Enter the document ID **1162581**

**Next step:** "Final steps", Page 37

## 6 Final steps

### 6.1 Connecting the encoder to the downstream electronics

#### WARNING

##### **Danger of electric shock due to plug connections under voltage!**

Connecting and disconnecting live cables and plug connections in the equipment can result in death or serious injury.

- Only connect and disconnect cables and plug connections when no current is flowing through them
- Disconnect the downstream electronics from power before connecting the product
- For cables without connectors, pay attention to the pin layout

- ▶ Connect the encoder to the downstream electronics

#### NOTICE

##### **Property damage resulting from incorrect routing of the connecting cable!**

Connecting cables may become damaged as a result of incorrect routing.

- ▶ Observe the maximum permissible bend radii
- ▶ Do not cross connecting cables in drag chains
- ▶ Route connecting cables professionally



For more information on the cable characteristics and cable routing, refer to the **Cables and Connectors** brochure.

- ▶ [www.heidenhain.com/documentation](http://www.heidenhain.com/documentation)
- ▶ Enter the document ID **1206103**



For more information on the pin layouts of pre-assembled cables, refer to the **Cables and Connectors** brochure.

- ▶ [www.heidenhain.com/documentation](http://www.heidenhain.com/documentation)
- ▶ Enter the document ID **1206103**



For more information on sources of interference, refer to the **Interfaces of HEIDENHAIN Encoders** brochure.

- ▶ [www.heidenhain.com/documentation](http://www.heidenhain.com/documentation)
- ▶ Enter the document ID **1078628**

## 7 Removal

This chapter describes the disassembly of the product.

### 7.1 Safety precautions regarding removal

#### WARNING

##### **Live plug connections!**

If you disengage plug connections while the equipment is under power, this may result in fatal accidents or severe personal injury.

- ▶ Do not engage or disengage any connecting elements while the product is under power

#### WARNING

##### **Moving machine parts!**

Risk of injury due to moving machine parts depending on the installation location and the application

- ▶ Observe all of the machine manufacturer's notes on working on the machine (e.g., always disconnect the machine from the power supply)

#### CAUTION

##### **Fragile carrier material of the graduation!**

Risk of injury from splinters and sharp edges of the carrier material

- ▶ Wear protective gloves and safety goggles
- ▶ Do not bend or deform the measuring standard excessively

### 7.2 Removing the scanning head

- ▶ Remove the scanning head in the reversed sequence of mounting.  
**Further information:** "Mounting the scanning head", Page 25

### 7.3 Removing the scale tape



Further information can be found in the **Disassembly Instructions**.

- ▶ [www.heidenhain.com/documentation](http://www.heidenhain.com/documentation)
- ▶ Enter the document ID **1185755**

# HEIDENHAIN

## DR. JOHANNES HEIDENHAIN GmbH

Dr.-Johannes-Heidenhain-Straße 5

**83301 Traunreut, Germany**

☎ +49 8669 31-0

☎ +49 8669 32-5061

info@heidenhain.de

**Technical support** ☎ +49 8669 32-1000

**Measuring systems** ☎ +49 8669 31-3104

service.ms-support@heidenhain.de

**NC support** ☎ +49 8669 31-3101

service.nc-support@heidenhain.de

**NC programming** ☎ +49 8669 31-3103

service.nc-pgm@heidenhain.de

**PLC programming** ☎ +49 8669 31-3102

service.plc@heidenhain.de

**APP programming** ☎ +49 8669 31-3106

service.app@heidenhain.de

**www.heidenhain.com**